

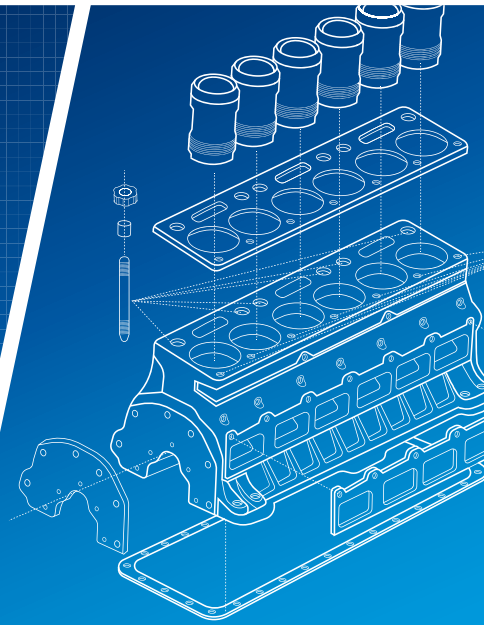

BOWERS GROUP

PARTNERS IN PRECISION

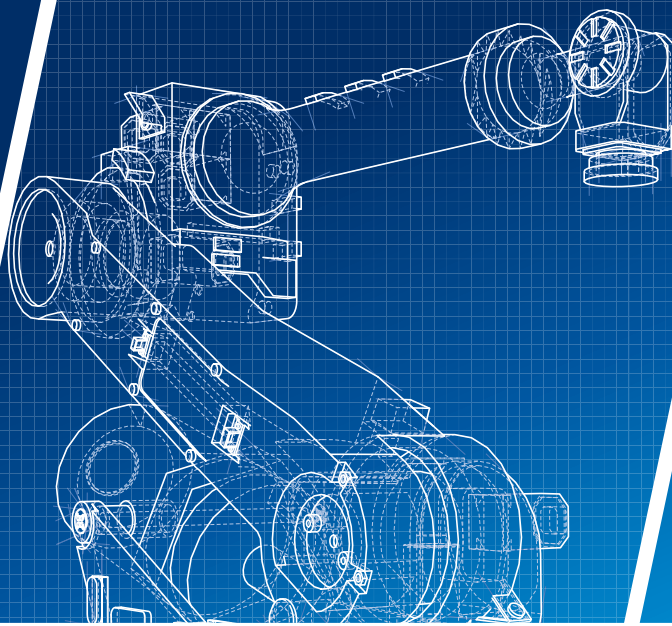

XT GROOVE SETS

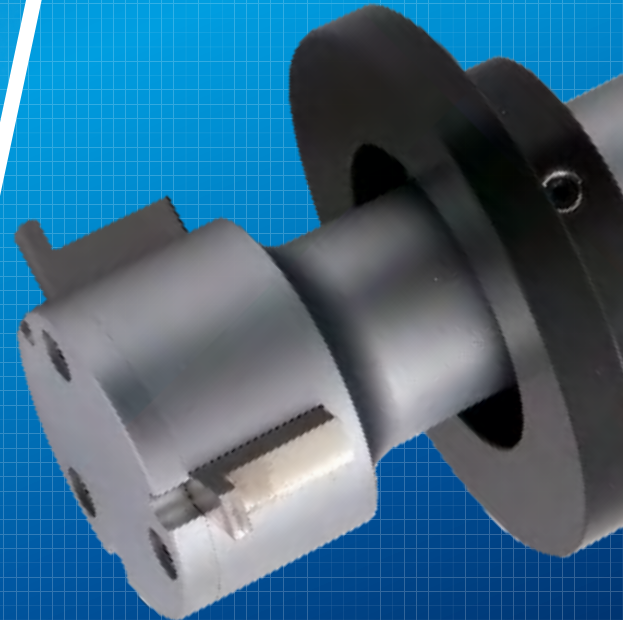
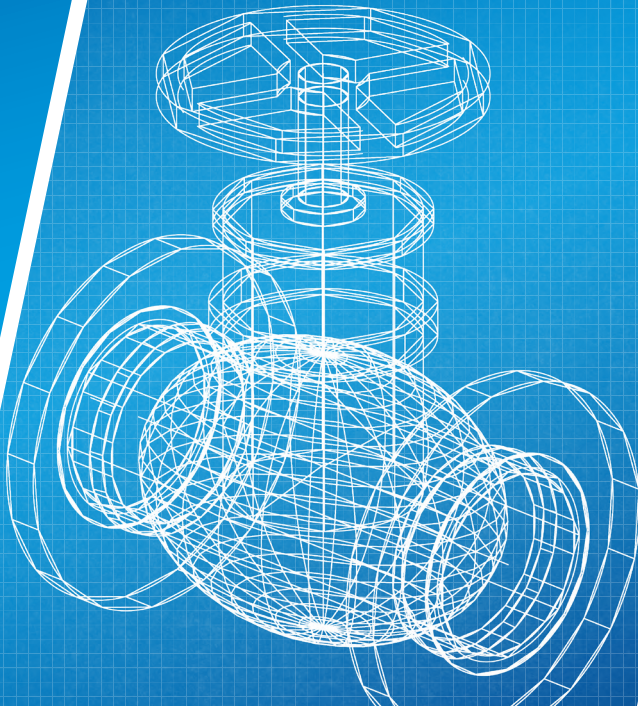

Bowers XT Precision Groove Diameter Measurement

Bowers XT3 digital internal micrometers offer a new ergonomic design - including a larger and clearer LCD display - along with IP67 electronics protection, proximity output with built-in Bluetooth; both allow bi-directional communication giving greater flexibility for data acquisition and storage.

The XT Groove sets are based on the standard self-aligning 3-point XT head design but with a stepped anvil to allow entry into grooved for fast and repeatable groove diameter measurement. The gauge is set using the calibrated setting rings provided and each ring size is stored in the gauge memory enabling quick and easy setting with each head change.

The trigger action pistol-grip controller enables the operator to retract the anvils instantly and pass the gauge through the entry diameter, then extend the anvils to engage with the groove diameter for an immediate absolute measurement.

Other versions of the standard XT head are also available for internal threads, splines, slots, deep hole and many more applications.

Standard XT Groove Set Features

- Generic anvil profile suits common groove sizes – see table
- Sets available to cover diameters 6 – 100mm (1/4" – 4")
- 3 point, self-centring, interchangeable heads for repeatability
- 0.001mm 0.00005" resolution
- Depth stops included
- Extensions available
- IP67 sealed
- Setting rings with UKAS certificates included
- Bluetooth with free data collection App

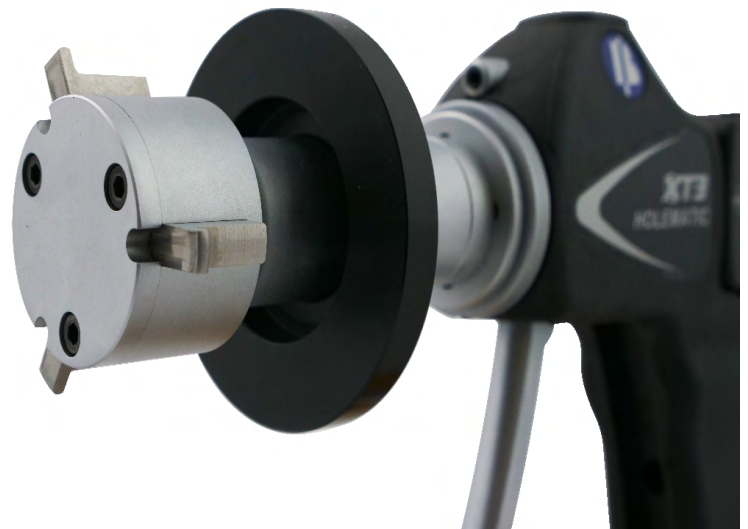

DATA TRANSMISSION

Code No	Description
30-926-6721	Sylvac Proximity USB Cable
30-981-7100	USB Dongle BT Smart for PC/D300S/D400S



SP-SXTH5M-BT-GRO

The Sylvac Smart and Sylvac Anywhere apps allows communication with Bowers Bluetooth Android 8.0
IOS 10 Bluetooth 4.0 required

Set Descriptions & Individual Heads

Standard Groove Anvil Detail

Minimum entry diameter:
0.3mm / 0.012" below minimum

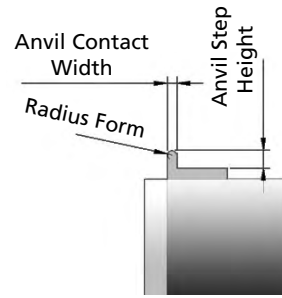

XT HOLEMATIC GROOVE SETS:

Code No	Set Range	Included Heads	Anvil Step Height	Anvil Contact Width	Depth Stop OD	Setting Ring Sizes
SP-SXTH10M-BT-GRO	6-20mm	6-8mm	1.25mm	1.5mm	18mm	8mm
		8-10mm	1.25mm	1.5mm	20mm	
		10-12.5mm	1.5mm	1.5mm	22mm	12.5mm
		12.5-16mm	2.0mm	1.5mm	26mm	
SP-SXTH10I-BT-GRO	1/4" - 3/4"	16-20mm	2.5mm	1.5mm	33mm	20mm
		1/4" - 5/16"	0.049"	0.059"	0.709"	5/16"
		5/16" - 3/8"	0.049"	0.059"	0.787"	
		3/8" - 1/2"	0.059"	0.059"	0.866"	1/2"
SP-SXTH5M-BT-GRO	20-50mm	1/2" - 5/8"	0.079"	0.059"	1.024"	
		5/8" - 3/4"	0.098"	0.059"	1.299"	3/4"
		20-25mm	3.175mm	2mm	39mm	20mm
		25-35mm	5.5mm	2mm	45mm	35mm
SP-SXTH5I-BT-GRO	3/4" - 2"	35-50mm	4mm	2mm	60mm	
		3/4" - 1"	0.108"	0.079"	1.535"	3/4"
		1" - 1 3/8"	0.217"	0.079"	1.772"	1 3/8"
SP-SXTH6M-BT-GRO	50-100mm	1 3/8" - 2"	0.157"	0.079"	2.362"	
		50-65mm	8mm	3mm	80mm	65mm
		65-80mm	8mm	3mm	95mm	80mm
SP-SXTH6I-BT-GRO	2" - 4"	80-100mm	10.5mm	3mm	115mm	
		2" - 2 5/8"	0.315"	0.118"	3.150"	2 5/8"
		2 5/8" - 3 1/4"	0.315"	0.118"	3.740"	3 1/4"
		3 1/4" - 4"	0.413"	0.118"	4.528"	

INDIVIDUAL HEADS

Code No	Range
XTHD6M-GRO	6-8mm
XTHD8M-GRO	8-10mm
XTHD10M-GRO	10-12.5mm
XTHD12M-GRO	12.5-16mm
XTHD16M-GRO	16-20mm
XTHD20M-GRO	20-25mm
XTHD25M-GRO	25-35mm
XTHD35M-GRO	35-50mm
XTHD50M-GRO	50-65mm
XTHD65M-GRO	65-80mm
XTHD80M-GRO	80-100mm
XTHD6I-GRO	1/4 - 5/16"
XTHD8I-GRO	5/16 - 3/8"
XTHD10I-GRO	3/8 - 1/2"
XTHD12I-GRO	1/2 - 5/8"
XTHD16I-GRO	5/8 - 3/4"
XTHD20I-GRO	3/4 - 1"
XTHD25I-GRO	1 - 1 3/8"
XTHD35I-GRO	1 3/8 - 2"
XTHD50I-GRO	2 - 2 5/8"
XTHD65I-GRO	2 5/8 - 3"
XTHD80I-GRO	3 1/4 - 4"

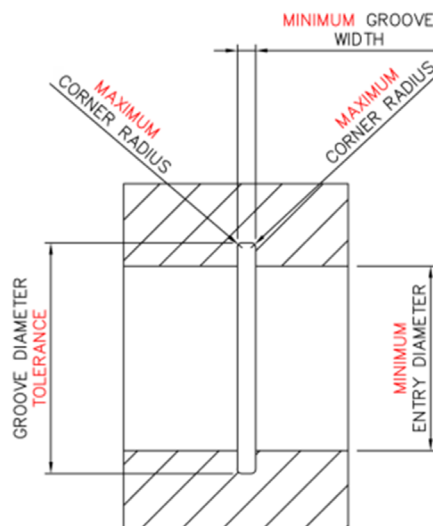

Custom Groove Set

If our generic groove anvil profile is not suitable for your application, please provide us with these 4 dimensions for a specific offer.

We will design a bespoke head that will fit your specific application.

[Enquire Here](#)



BOWERS GROUP

